

floor-fastening plates

BFPK

for levelling elements LBE PH



floor-fastening plates BFPK for levelling elements LBE PH

These fastening plates are made of high-strength compound material, precision-milled to shape and equipped with elongated holes for ground dowels. Suitable to keep machines in place, where strong horizontal forces and the tendency to wander occurs. Installation is simple and can be applied even retroactively with already existing set-ups in combination with our levelling elements LBE PH.

Available in 3 sizes: floor-fastening plate BFPK 7 suitable for levelling elements LBE 7 PH (base diameter 76 mm), floor-fastening plate BFPK 10 suitable for levelling elements LBE 10 PH (base diameter 105 mm) and floor-fastening plate BFPK 13 suitable for levelling elements LBE 13 PH (base diameter 135 mm).

optional:

suitable bolt anchors for fastening in the ground (refer to the bottom of this document - to be ordered separately)

produkt highlights:



high-strength compound material
3 sizes available

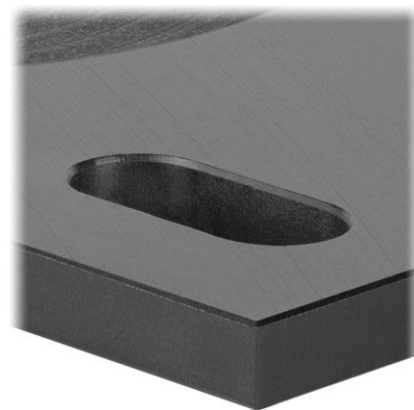

elongated holes for bolt anchors
milled to precision



easy installation



applicable also retroactively with
already existing machine installations

floor-fastening plates BFPK for levelling elements LBE PH

milled compound material										
		suitable for	lxb	h	t	d	e	f	x	y
description	article number	levelling elements	mm	mm	mm	mm	mm	mm	mm	mm
BFPK 7	1998 0001	LBE 7 PH	130x100	11	6	71	11	22	12	20
BFPK 10	1998 0002	LBE 10 PH	182,5x125	11	6	99	13	35	17	20
BFPK 13	1998 0003	LBE 13 PH	229,5x159	11	6	129,5	18	40	15	20



BFPK 7
here shown with LBE 7 PH M16x100

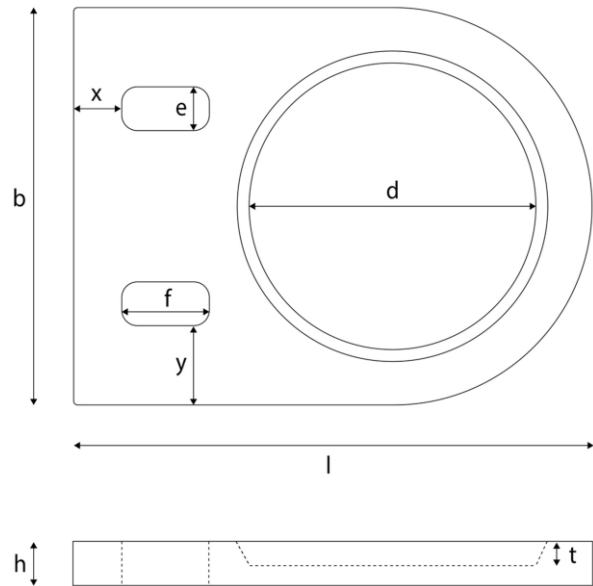

schematic drawing
BFPK



BFPK 10
here shown with LBE 10 PH M20x100



BFPK 13
here shown with LBE 13 PH M24x150

bolt anchors FAZ

for securing the floor-fastening plates BFPK
in the ground



zinc galvanized (gvz)

type		thread	key width	nominal drill diameter	min. drill hole depth with stick-through mounting	dowel length	max. net length	assembly torque
		Ø x length	SW	d ₀	h ₂	l	h _{ef,max./h_{ef,min.}}	
description	article number	mm	mm	mm	mm	mm	t _{fix}	Nm
suitable for BFPK 7								
FAZ II 10/20 gvz	10320 00010	M 10 x 63	17	10	95	105	20/40 mm	45
suitable for BFPK 10								
FAZ II 12/10 gvz	10320 00007	M 12 x 61	19	12	100	110	10/30 mm	60
suitable for BFPK 13								
FAZ II 16/5 gvz	10320 00016	M 16 x 64	24	16	115	128	5/25 mm	110

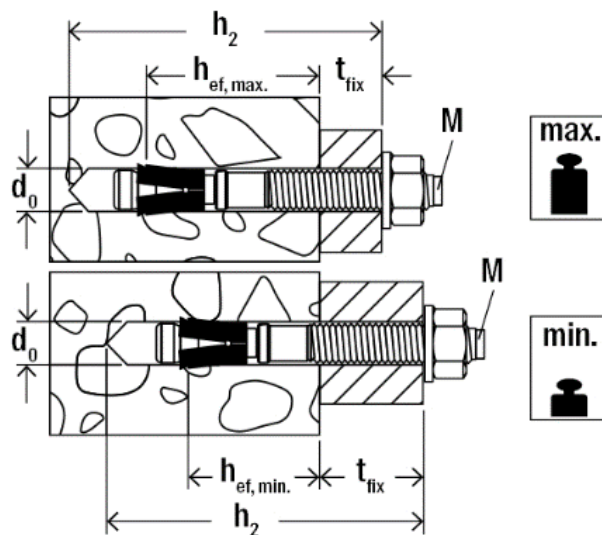

mounting scheme
bolt anchors FAZ

picture of the bolt anchor and schematic drawing on this catalogue page courtesy fischer Dübel company

Technical modifications subject to change! Any previous versions of this document are herewith null and void!